

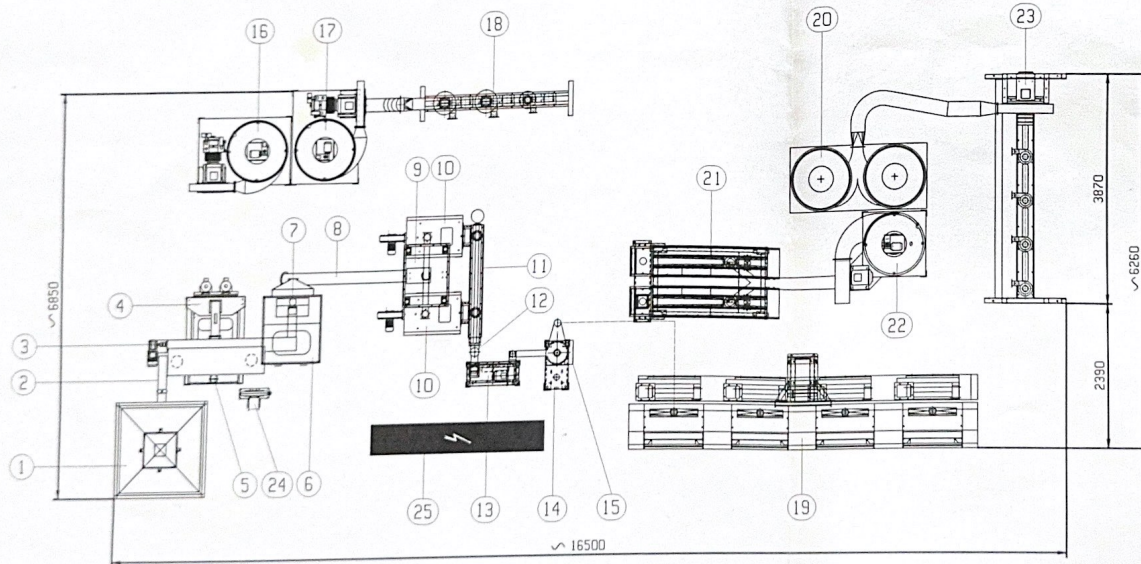

MILLING PLANT AGS4/3500-GR-1SE



1. RECEPTION HOPPER (CAPACITY 7.8M³);
2. VOLUMETRIC DOSING UNIT;
3. CONVEYOR TO FEED THE CLEANER;
4. CLEANING SIEVE;
5. SIEVE SUCTION PIPE;
6. VIBRATING STONE-RAKE;
7. STONE-RAKE SUCTION PIPE;
8. SCREEN CONVEYOR;
9. RECEPTION HOPPER FOR DEGERMINATOR;
10. N°2 DRY MAIZE DEGERMINATOR;
11. HORIZONTAL SCREEN CONVEYOR;
12. VERTICAL SCREEN CONVEYOR;
13. ROTATIV CLASSIFIER;
14. HUMIDIFIER MAIZE INTENSIV UNIT DRAPER;
15. HUMIDIFIER MAIZE CONTROL PANEL;
16. CLEANING UNIT FILTER;
17. DEGERMINATOR UNIT FILTER;
18. COLLECTION OF DEGERMINATED FAT PRODUCT + SUB-PRODUCT;
19. FOUR PASSAGE ROLLER MILL WITH PNEUMATIC CONVEYOR;
20. MILL FILTER UNIT;
21. PURIFIER MOD. SE24-500/500;
22. PURIFIER FILTER UNIT;
23. SACK HATCHES FOR PRODUCTS;
24. MILLING AND PNEUMATIC CONVEYOR OF THE IMPURITIES;
25. CONTROL PANEL OF MILLING PLANT.

		IMPianto: AGS4/3500-GR-1SE	
		CLIENTE:	
Disegnato: D. S.		Data: 16/02/06	
Scale: 1/50	Nota: LAY-OUT STANDARD	MOD/03: LAYA1411ING	00
MODIFICHE: INCLASSE			